

The Chinese invented all of this...



We are going to explore kites!

It is believed that kites were made and flown in China and Japan more than 2000 years ago. Later they spread into other Asian countries, like India and Korea. However, the kite only appeared in Europe by about the year 1600.

The first kites had sails made of paper or light fabrics such as silk. The poles were made from bamboo sticks, or other strong but flexible woods, and the kite line was made from string or twine.

Activity 1:

Stick your kite pictures on the map to show where they came from.

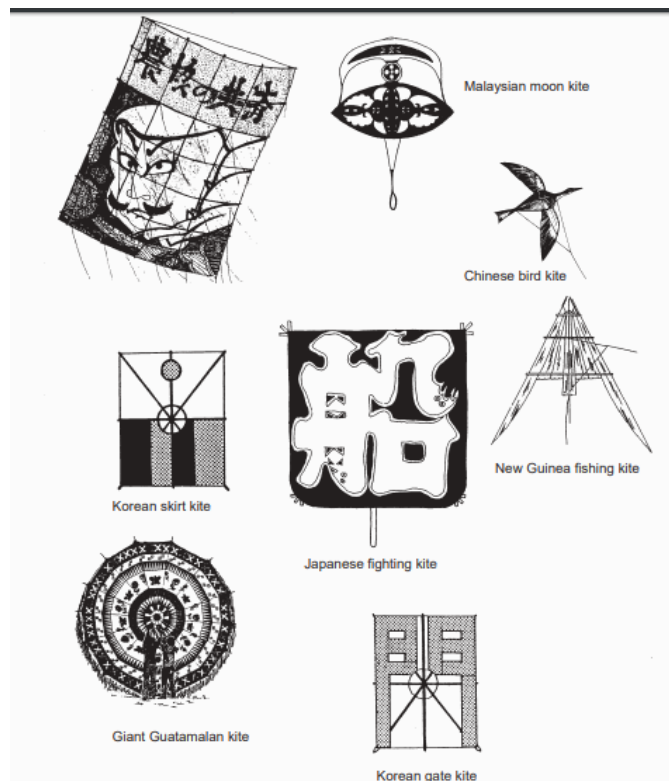

How does a kite fly?

The principle that makes a kite fly is the same as that which keeps an airplane aloft. An airplane creates its own wind by its speed through the air. On a calm day running with a kite in an open space produces the same effect. The kite rises because currents of air, moving parallel to the ground, strike the face of the kite and force it backward.

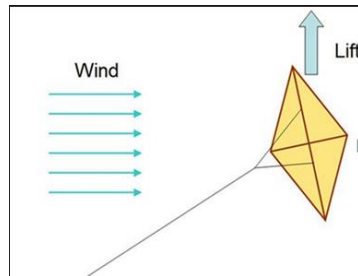

Activity 2:

Now it is your turn - you are going to make a Scott Sled kite.

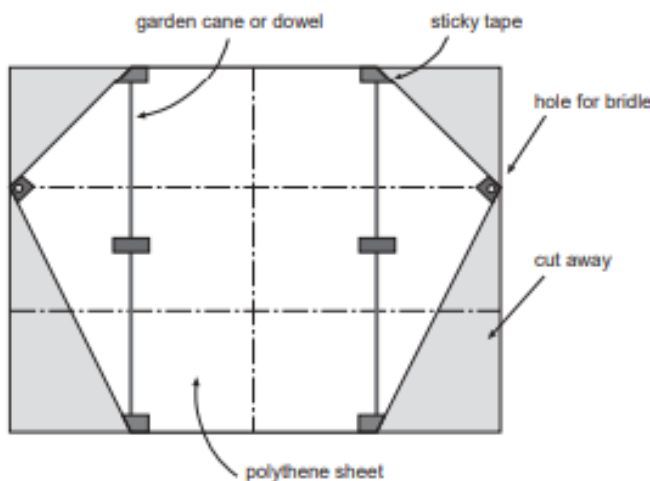

In 1950 William M. Allison in the USA invented a completely new kind of kite. This design was improved by Frank Scott in 1964.

The Scott Sled kite is very simple to make. It can be made almost any size using the shape shown here.

Using the squares for guidance, make a large copy of this shape on a polythene bin liner or carrier bag.

Use sticky tape to fix the rods in place and to strengthen the corners where the bridle lines are attached. You could try vents (holes) in the lower half, or add a strip of polythene as a tail.

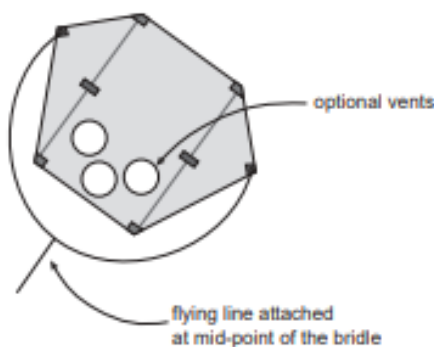

Plan your own investigations to see if the shape and number of vents in the bottom half of the kite affect the way in which the kite flies.

Does the type of tail you add make any difference?

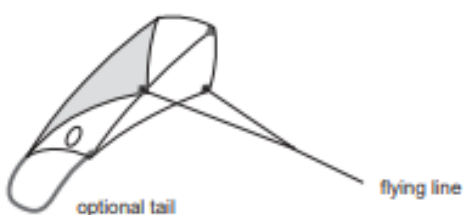

In each investigation

- **What will you change?**
- **What will you keep the same?**
- **What will you look for, or measure?**
- **How will you record your observations?**
- **What is the question you are trying to answer?**